

Overview

SuperGiga is a new addition to the GIGA series systems, the ultra high bandwidth product family of LaserBytes Compact portfolio. SuperGiga systems provide Gigabit Ethernet wire speed full duplex data transfer up to 2500 meters. Due to the compact mechanical design and factory set optical system SuperGiga requires no adjustment or configuration on site, which makes the installation fast and easy. SuperGiga systems feature multibeam technology and LaserByte's patented Automatic Inbound Power Control, which guarantee outstanding link availability. The product can be ordered with IP based NMP compatible device management that allows remote control and monitoring of the equipment. Because they use infrared light as transmission medium, LaserByte systems do not require frequency licenses and the transmission is not affected by electro-magnetic interference. The concentrated laser beam is extremely hard to tap, even to discover since it can not be detected by spectrum analyzers or similar instruments. The transparent and wire speed data transfer together with virtually zero latency assures the easy integration of the system in all environment

Product Description

The SuperGiga system comprises of two Laser Heads, two Outdoor Interconnection Units (OIU) and two sets of interconnection cables one at each end. The Laser Heads are installed outdoors, where a clear optical path exists between the two sites. Next to the head the Outdoor Interconnection unit provides fast and easy interconnection between the laser head and the cable coming from the network equipment. Moreover the OIU houses the Power Supply Unit (PSU) of the system and the network interface. The PSU provides the low voltage power required to operate the laser head while the data port offers direct connectivity for standard network equipments. Both single mode and multimode fiber optic interfaces are available for easy network integration. The system contains built in signal monitoring unit, which features a visual signal strength indicator and LINK status information accessible on the rear of the head assembly.

The optional IP Based Management Hardware is placed in an Indoor Interconnection Unit (IDU). The bar graph of the IDU displays the actual signal strength level while the LED indicators show the presence of Minor or Major alarm condition. With the help of the relay contacts an external alarm monitoring equipment may be connected to the system to further process the alarm signals. In addition to the above LaserByte software allows the monitoring of the link's operation through a proprietary graphical interface (GUI) via Ethernet or RS-232 ports or a third party SNMP manager via TCP/IP connection.



Key Features:

- Free Space, Wireless Communication
- Compact System Design
- Full Duplex Wire Speed Connectivity
- Industry Standard Fibre Optic Interfaces
- Secure Data Transmission
- Quick Installation & RE-DEPLOYMENT
- Built-in signal monitoring

Applications:

- Provide GIGABIT Speed Wireless Connectivity instead of Fiber or where Fiber is not available
- Interconnect LANs in Campus or Industrial Environment
- High Bandwith Connection to the Internet
- VoIP Applications
- Backbone Connectivity in Metropolitan or 3G Wireless Networks
- Emergency Backup to Fiber

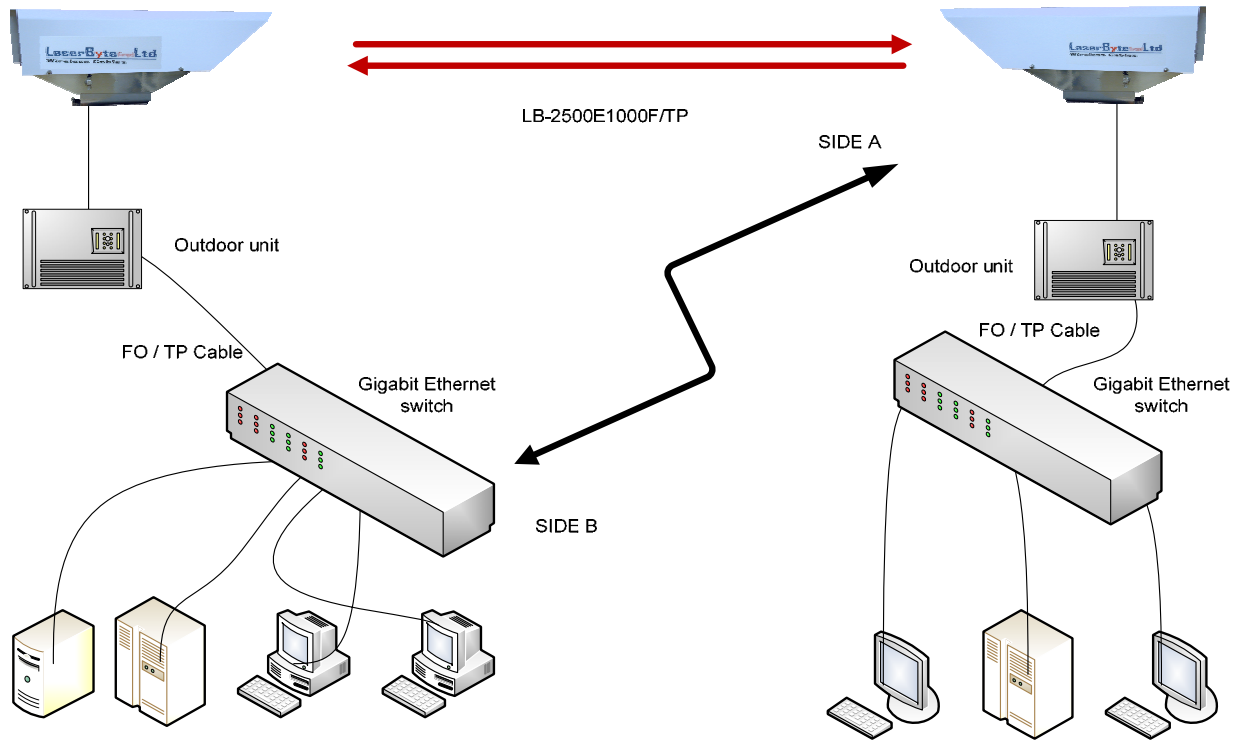

LaserByte SuperGiga

Laser Based Free Space Optical Communication System

ELECTRICAL CHARACTERISTICS

Light Source	Laser Diode
Laser Diode Power	8x25mW
Detector	Si APD Photodiode
Dynamic Range	>30 dB
Bandwidth	1250 Mbps
BER	10^{-9}
System Latency	<50 ns

DATA IN/OUT

Gigabit Ethernet (SM LX optional)	TP or MM fiber SX interface at 850nm with SC connectors
-----------------------------------	---

PHYSICAL CHARACTERISTICS

Head Housing	Aluminium Alloy
Weight	32 kgs
Dimensions (with cover and Alignment Unit, mm)	750 x 467 x 480

ORDERING INFORMATION

LB-2500E1000/xx/yyy/z	LaserByte SUPERGIGA LINK. 1 Gbpt/sec. Ethernet interface. Maximum 1000 m distance between heads, MM FO connection
-----------------------	---

xx - interface type (tp, sm,mm), yyy - power type (115,230,-48), z - window heater option (s,h)

OPTIONAL MODULES

LB-SM-OPT	Single Mode Driver Option, LX IF (1300nm) with SC connectors (additional cost to MM Optical Head per END)
LB-MGM-BASE*	Basic IP based management system (inc. 2 x LB-MGM-HW and BitView), 110 VAC or 230 VAC PSU (per LINK)

ENVIRONMENT

Operating Temperature	-25 to +60 Centigrade
Storage Temperature	-40 to +80 Centigrade
Humidity	95% non condensed
Protection Rating	IP65

POWER

Power Required	230VAC, 50W max.(110VAC or 48VDC opt.)
Power to the Head	28VA
Power to the Head	2 x 8VDC +30VDC, 2x 1A max.

OPTICAL CHARACTERISTICS

Wavelength	785 nm
Beam Divergence	0.5 - 1.5 mrad
Receiver acceptance angle	8.5 mrad

Complete link management solution with PC based graphical interface and SNMP agent up to 8 links. See pricelist for full list of optional items.



Supplying Future Solutions
To The Home And Office

Net-Com (92) Limited
Unit 12, West Place,
Harlow, Essex, CM20 2BU
T: 01279 441505 F: 01279 441773